

## TurnCheck™ Series-10

TurnCheck Series-10 systems are precision optical shaft measuring instruments designed for shop floor environments. Rugged and reliable, TurnCheck Series-10 has a completely telecentric, large field of view optical system that accommodates parts with shaft diameters up to 100 mm. The granite base support for rotary provides a rigid base and isolates vibration.

- **Measure Within Seconds –**  
Shaft lengths up to 800 mm.
- **Collimated LED illumination –**  
Reduces distortion to provide superior image quality and improved measurement of critical dimensions of all feature types.
- **Shop-Floor Debris Protection –**  
Optics drop down below the stage when machine is not in use. Convenient air blow-off mounted to the front of the machine for cleaning parts prior to measurement.

### High-Performance Shaft Measuring Machine



TurnCheck 10|60 model with optional workstation shown.



# TurnCheck™ Series-10

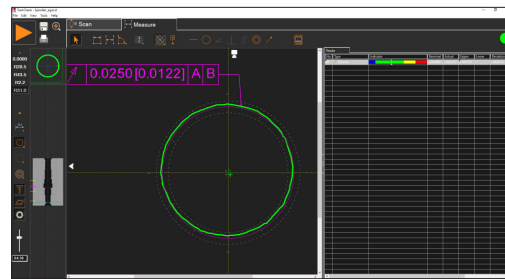
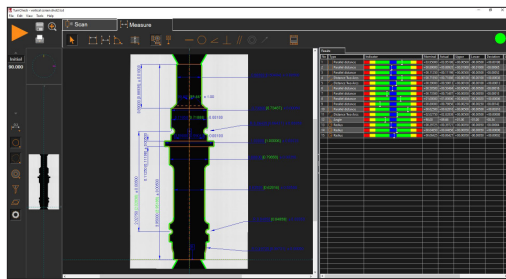

## Measurement & Analysis Capabilities:

- Automatic data point generation and simple feature extraction
- Advanced image analysis technology
- Program using DXF CAD models
- True high definition of part image display
- Optional SmartProfile® software for 3D analysis and advanced GD&T

## Rugged, Easy To Use Design:

- Easy loading – one-handed tailstock operation
- Built-in light curtain to safeguard the operator during automatic measurement
- Additional optional workholding kits available for parts that do not have centers

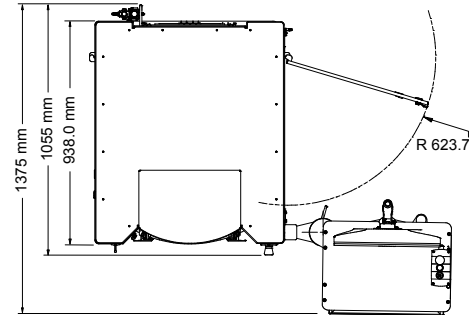
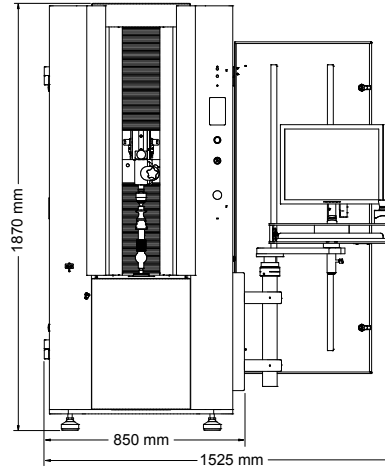

System Weight: 530 kg  
Shipping Weight: 630 kg

Series-10	10 40	10 60	10 80
<b>Measurement Capacity &amp; Machine Size*</b>			
Vertical Measuring Range	400 mm	600 mm	800 mm
Maximum Diameter Measuring Range	100 mm	100 mm	100 mm
Maximum Part Size	175∅ mm x 400L mm	175∅ mm x 600L mm	175∅ mm x 800L mm
Machine Size	850 mm x 1055 mm x 1870 mm	850 mm x 1055 mm x 1870 mm	850 mm x 1055 mm x 1870 mm
Machine Size with Optional Workstation	1525 mm x 1055 mm x 1870 mm	1525 mm x 1055 mm x 1870 mm	1525 mm x 1055 mm x 1870 mm
* Between standard centers.			
<b>System Performance</b>			
Vertical Scanning Speed	100 mm/sec		
Rotational Scanning Speed	60 RPM		
Vertical Scale Resolution	0.1 µm		
Video Edge Resolution	0.5 µm		
Rotational Scale Resolution	0.001 degrees		
Rated Spindle Load	80 kg		
<b>Accuracy**</b>			
Diameter Measurement	1.8 + D/100 µm		
Diameter Repeatability	1.0 µm		
Length Measurement	3.5 + L/150 µm		
Length Repeatability	3.0 µm		
<b>Rated Environment &amp; Facilities</b>			
Power Requirements	Power: 100-120 VAC or 200-240 VAC, 50/60 Hz, 1-Phase, 650 W		
Compressed Air Requirements	Air supply pressure: 0.4 MPa; Minimum Flow capacity: 175 l/min; Air quality ISO 8573-1:2010 Class 4.3.4 or better		
Safe Operating Environment	15-30 °C, non-condensing		
Rated Environment	Temperature 18-22 °C; 30-80% humidity; vibration <0.001g below 15 Hz		

\*\*Where D, L = measuring length in mm. Applies to thermally stable system in rated environment. Maximum rate of temperature change: 1 °C/hour. Maximum vertical temperature gradient: 1 °C/meter. Applies to a work piece with its center of mass located on the spindle axis.



World Headquarters: Rochester, NY, USA • 585.544.0400 • www.ogpnet.com

OGP Shanghai Co, Ltd: Shanghai, China  
86.21.5045.8383/8989 • www.smartscope.com.cn

OGP Messtechnik GmbH: Hofheim-Wallau, Germany  
49.6122.9968.0 • www.ogpmesstechnik.de

Optical Gaging (S) Pte Ltd: Singapore • 65.6741.8880 • www.smartscope.com.sg